



DLA Contract
SPE8EC-19-D-0039



GSA Contract
GS-30F-0027R



LOWBOY, 55 TON

55LB560867



PRD: 00560867 A.1



LOWBOY, 55 TON HGG

3 AXLE, DETACHABLE NON GROUND BEARING,
MAXIMUM PAYLOAD 110,000 LBS



HIGH QUALITY STEEL

NuStrength™
HIGH PERFORMANCE STEEL

NuStrength™ HR100

HIGH PERFORMANCE STEEL

ULTRA HIGH STRENGTH SHEET
100 KSI / 700 MPA SHEET STEEL COMPARISON

Melted and Manufactured in the USA

Constructed with T-1 100K PSI yield strength Steel. The High Tensile Steel ensures the designed camber is retained, and allows for a longer product service life.

WARRANTY



Globe Trailer's 10 year structural warranty on all lowboys is the best in the industry. Most competitors offer only a 5 year warranty. This shows how committed Globe Trailers is to it's customers.

DECKING OPTIONS



Oak: Standard.

Apitong: Best strength to weight ratios of natural woods.

Rumber: Composite which is impervious to fluids, mud, oil and UV rays.

HEAVY DUTY FRONT OUTRIGGERS



Globe Trailers fabricated heavy duty pullout front outriggers provide added strength which is needed to accommodate the initial force when loading equipment. The outrigger is held in position with a spring loaded locking pin.

STEMCO WHEEL WARRANTY



5 year wheel end warranty. Guardian wheel seals, Pro-Torq spindle nuts and Sentinel hub caps.

STANDARD FRONT RAMPS



Standard Steel Front ramps, for ease of front loading.

OPTIONAL FLIP BOX



Flip box length options are available to achieve longer swing clearances when needed for longer truck frames or when coupling to single or multi-axle jeeps.

EXTENDABLE DECK

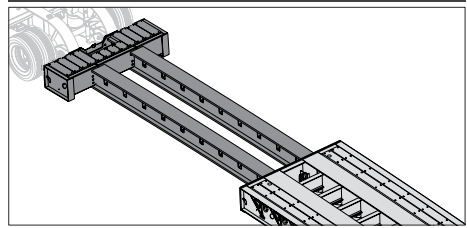

The extendable deck allows for increasing the deck length to accommodate various load lengths.

AIR BAGS



30K pound rated large diameter air bags are standard. This allows for lower operating pressure and higher capacity when needed.

22" DECK HEIGHT



With a standard deck height of 22", Globe Trailers have lower overall height, which allows taller loads to be hauled.

ADDED SECURITY



Globe Trailers air lock with safety bar and spring extended pin ensures that the gooseneck locking pin will remain secured even if air pressure is lost.

V-STYLE GUIDE



V-Style guide with front tapered beams helps position the gooseneck locking pin, which makes hooking up to a Globe Trailer fast and easy. The locking pin guide rim helps prevent the gooseneck locking pin from coming loose in transit.

CENTRALLY LOCATED FITTINGS

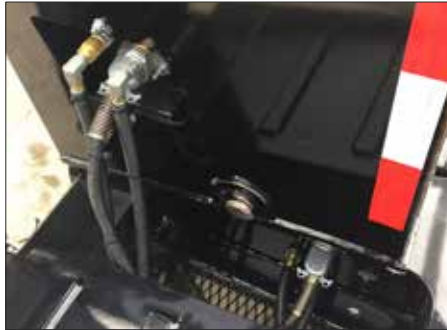

Air, electric and hydraulic (when applicable) fittings are all centrally located at the base of the gooseneck inside a bolster. This makes for quick and easy connect and disconnect. The fittings are protected from possible contact with equipment being loaded or unloaded.

COLOR OPTIONS



Globe Trailers can powder coat to the color of your choice.

COLOR CODED HOSES



Color coded air hoses allow for easy trouble shooting and maintenance.

STINGER



The Stinger Assembly increases the wheel base of the trailer when attached to the rear trailer frame. The Stinger Assembly is used for heavy hauling situations where regulations and specific axle loads must be adhered.

MULTI POSITION RIDE HEIGHT



Multi Position Ride Height options. Makes adjustments for various 5th wheel heights easy and allows for larger ground clearance or lower deck height.

LIGHTING SYSTEM



All Lighting is LED and mounted in rubber grommets to DOT standards.

POLYURETHANE VS RUBBER BUSHING



Reduced Maintenance	Increased Maintenance
Increased Trailer Lifetime	Needs Replacement
Increased Trailer Performance	Reduces Trailer Performance
Weather Resistant	Damaged from Weather



All Globe Trailers are 100% powder coat finished. The entire process takes place at Globe's manufacturing facility. This eliminates the possibility of contamination occurring in transit between process phases. The process starts with sandblasting the trailer to near white, preheating the trailer steel in a dedicated, gas fired oven to optimum bonding temperature and applying an electrostatically charged zinc rich primer. The trailer then goes back in the oven to allow the primer to bond. After the primer has bonded, a top coat chosen from one of Globe Trailers' 188 color options is applied before once more going back in the oven to cure. The result is a durable, easily cleaned finish that protects the trailer from corrosion and ensures a long service life.

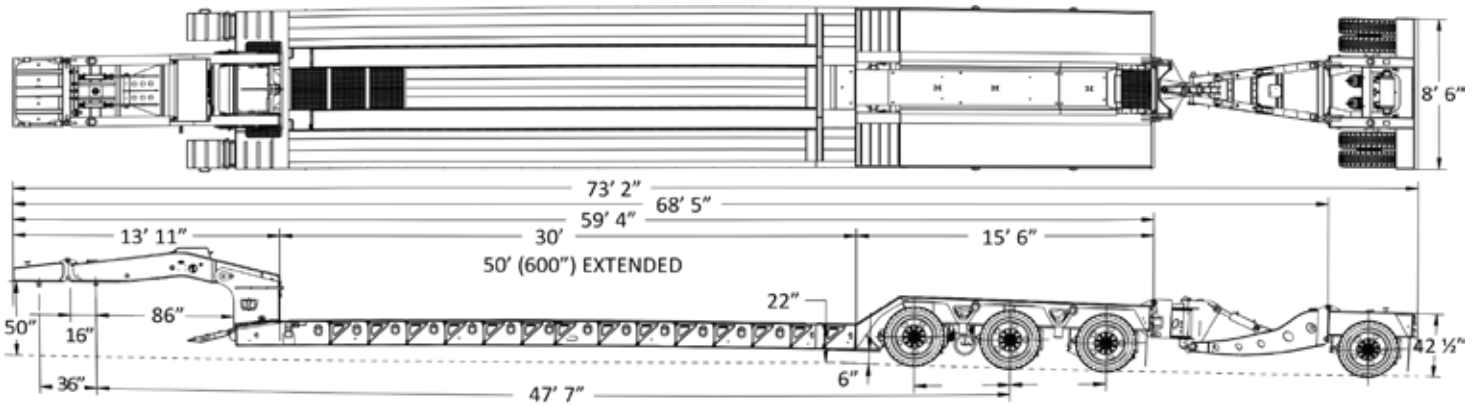

Trailer Model: GTBN553-58-30-HGG

Weight: Apx. : 32220 ± lbs

Overall Length	Overall Width	Gooseneck Length	Lower Deck Length	Lower Deck Height	Rear Deck Length	Rear Deck Height	Ground Clearance
59' 4"	8' 6"	13' 3"	30'	22" loaded	15' 6"	42 1/2"	6"

Main Deck	
Main Beam	16" T-1 Steel Std.
Centers	41" Standard
Side Rails	16" T-1 Steel
Crossmembers	10"
Spacing	12"
Outriggers	Full Height Removable
# Of D-Rings	13 Each Side
Front Ramps	Steel, 18" x 31" Standard
Concentrated Load	110,000 lbs in 12'
Rear Deck	
Riser	35° Rear Bridge Ramp
Rear Well Style	Boom & Bucket Well
# of D-Rings	2 each side
Set up for hydraulic powered flip	
Decking/Flooring	
Main Decking	1.75" Apatong Full Width
Wheel Covers	Steel Covered D-Plate
Well Decking	Removable V-Style - Full Length
Electrical	
Lights	LED Plus 2 - Rear Strobes
Connector	7 Way Connector
Safety Night Light Package w/ Battery	
Tires & Rims	
Tires	275/70R x 22.5 "H"
Rims	8.25 x 22.5 Hub Piloted Outer Aluminum
Hydraulics	
Wet Line Kit - Wing Nut Connection	
13HP Honda - Gas	

Axles, Suspension, & Running Gear	
# of Axles	3
Axle Spacing	60"
Axle Capacity	25,000 lbs
Brakes	16 1/2" x 7" - 25K
ABS	4S2M
Axle 1	Fixed Type 30/30 ABS
Axle 2	Fixed Type 30/30 ABS
Axle 3	Super Lift Type 30 Non-ABS
Air Ride Suspension adj.	
Auto Dump	
Gooseneck	
King Pin Style	Removable
King Pin Setting	16"
Swing Clearance	86"
5th Wheel Height	50"
King Pin	2"
Ride Height	5-Position
36" Flip Box & Set Up	
Finish	
Sandblast & Powder Coat	
Mud Flaps & Reflective Tape	
Flag Holders	

Dealer: